

FREESKETTINGEN

| CHAINS PITCHES | | | |
|----------------|---|---|---|
| |  |  |  |
| | 22,6 mm "A" pitch | 15,7 mm "B" pitch | 13,7 mm "C" pitch |
| W mm | 6 – 40 | 4 – 30 | 4 – 25 |
| L mm | 40 and more | 30 – 35 | 20 – 25 |

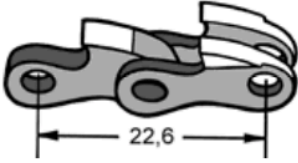
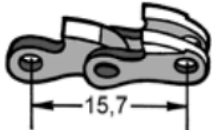
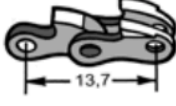
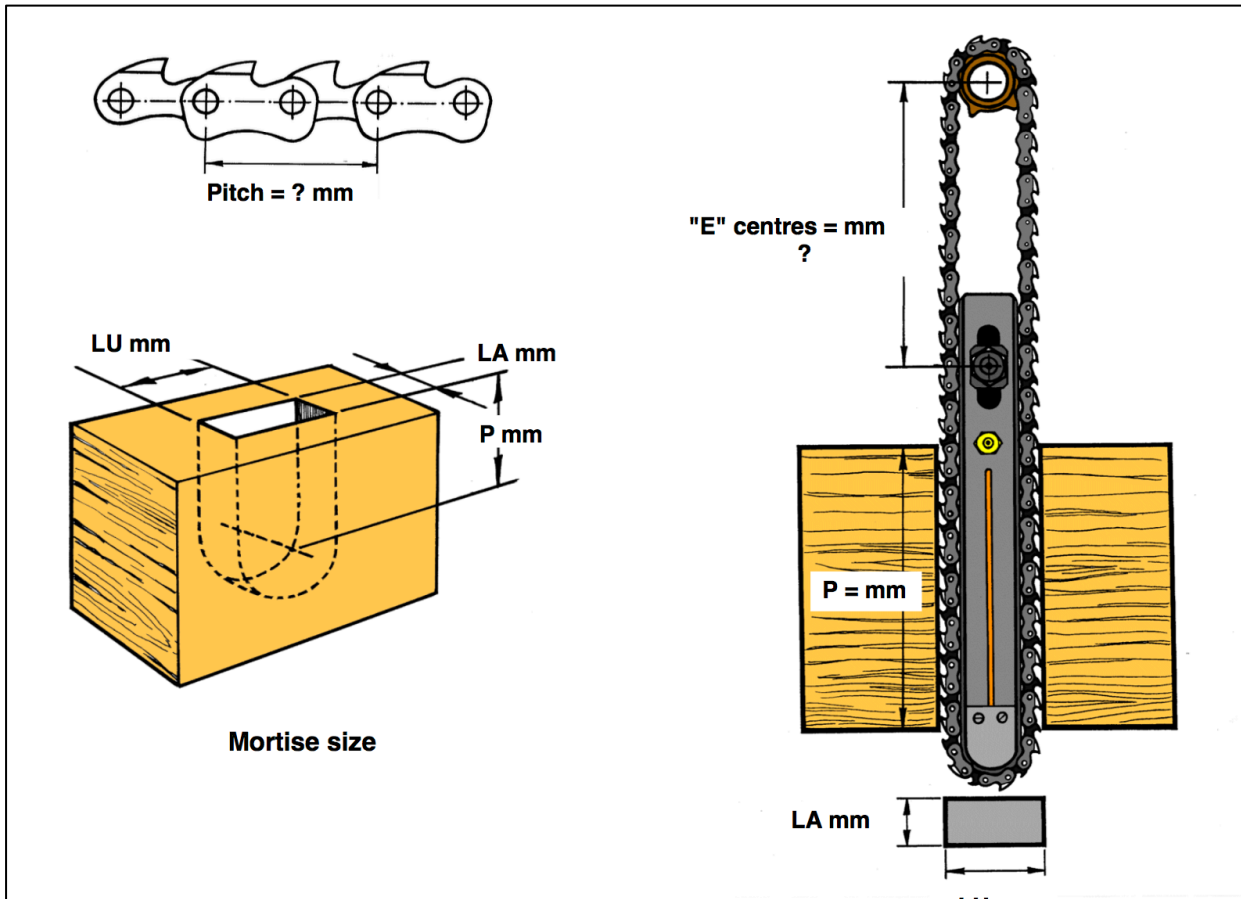

E = machine centres (normally 150 mm for stationary machines)
 LU = mortise length
 LA = mortise width
 P = mortise depth

TO SEND YOU AN EXACT OFFER WE NEED THE ABOVE MENTIONED SIZES.

