

# PC12MD

## Hardmetalen cilinderkopboren Carbide boring bits for hinges

Boren voor het maken van zuivere gaten in hard- en zacht hout en de meeste houtproducten.  
Schacht  $\varnothing$  10x30 mm.

Bits to drill clean holes in soft and hardwood and most wood products.  
 $\varnothing$ 10x30 mm shank.

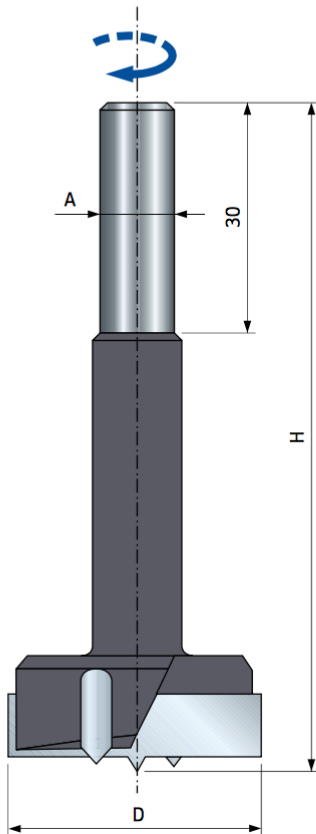

D mm	H mm	A mm	Z	Max. opm Max RPM	Code Code	SAP SAP
15	90	10 x 30	2+2		PC12MD0150	F03FA01872
16	90	10 x 30	2+2		PC12MD0160	F03FA01873
18	90	10 x 30	2+2		PC12MD0180	F03FA01874
20	90	10 x 30	2+2		PC12MD0200	F03FA01875
22	90	10 x 30	2+2		PC12MD0220	F03FA01876
24	90	10 x 30	2+2		PC12MD0240	F03FA01877
25	90	10 x 30	2+2		PC12MD0250	F03FA01878
26	90	10 x 30	2+2		PC12MD0260	F03FA01879
28	90	10 x 30	2+2		PC12MD0280	F03FA01880
30	90	10 x 30	2+2		PC12MD0300	F03FA01881
32	90	10 x 30	2+2		PC12MD0320	F03FA01882
34	90	10 x 30	2+2		PC12MD0340	F03FA01883
35	90	10 x 30	2+2		PC12MD0350	F03FA01884
38	90	10 x 30	2+2		PC12MD0380	F03FA01885
40	90	10 x 30	2+2		PC12MD0400	F03FA01886
45	90	10 x 30	2+2		PC12MD0450	F03FA01887
48	90	10 x 30	2+2		PC12MD0480	F03FA01888
50	90	10 x 30	2+2		PC12MD0500	F03FA01889
60	90	10 x 30	2+2		PC12MD0600	F03FA14709

