

FI02M

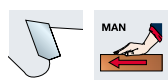

Grooving cutters with spurs Frese per incastri con rasanti

Brazed cutter with anti-kickback device for good quality grooving on soft and hardwood, both cross cutting and ripping, on chipboard, compressed laminated woods and MDF.

Fresa con limitatore di truciolo per incastri di ottima qualità su legni teneri e duri lungo vena e trasverso vena; su multistrato, truciolari, laminati ed MDF.

D mm	B mm	d mm	Z	R	Max RPM 1/min.	Code Codice	SAP SAP
100	4	22	2	4	13.300	FI02M BZ3	F03FS00658

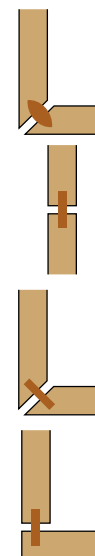
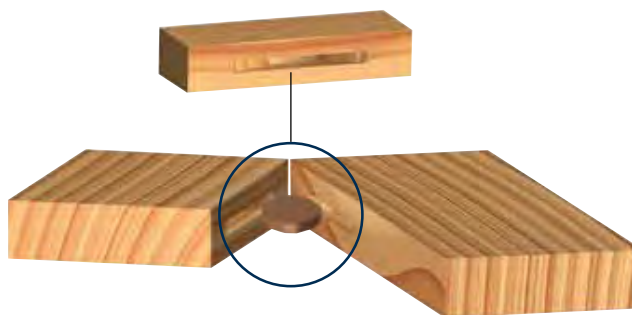
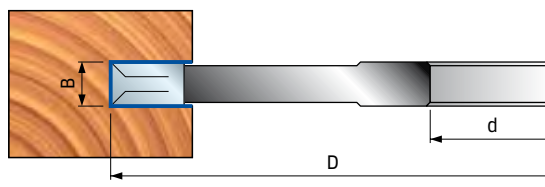

TG13M

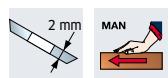

Grooving cutterheads Teste per incastri

D mm	B mm	d mm	Z	R	Max RPM 1/min.	Code Codice	SAP SAP
100	4	22	4	4	10.500	TG13M AA3	F03FC20271

Spare parts Parti di ricambio	Dimensions Dimensioni mm	Code Codice	SAP SAP
Coltello / Knife	18 x 1,9 x 18	CG03MAA310	F03FH02876
Ghiera / Nut	11,6 x 1,5 x 4	VT18M BA9	F03FA04483
Rasante / Spur	14 x 14 x 2	RG01MAA310	F03FH03034
Ghiera / Nut	9,4 x 1,7 x 4	VT18M DA9	F03FA04487
Vite / Screw	M4 x 3,2	VT05M BB9	F03FA04447
Chiave Torx / Torx key	T9	CB03M CA9	F03FA00165

